

Nominal data

Type	4312 T	
Nominal voltage	VDC	12
Nominal voltage range	VDC	8 .. 13.2
Speed	min ⁻¹	2800
Power input	W	5.0
Min. ambient temperature	°C	-20
Max. ambient temperature	°C	65
Air flow	m ³ /h	170
Sound power level	B	5.8
Sound pressure level	dB(A)	45

ml = Max. load · me = Max. efficiency · fa = Running at free air · cs = Customer specs · cu = Customer unit
Subject to alterations

4312 T

DC axial compact fan

Technical features

Housing material	Fibreglass-reinforced plastic (PBT)
Impeller material	Fibreglass-reinforced plastic (PA)
Mass	0.220 kg
Dimensions	119 x 119 x 32 mm
Direction of air flow	Air exhaust over bars
Direction of rotation	Clockwise, looking at rotor
Bearing	Ball bearings
Lifetime L10 at 40 °C	65000 h
Lifetime L10 at maximum temperature	35000 h
Connection line	Single strands AWG 22, TR 64, bared and tin-plated.
Motor protection	Protected against reverse polarity and locking.
Option	Alarm signal

4312 T

DC axial compact fan

Product drawing

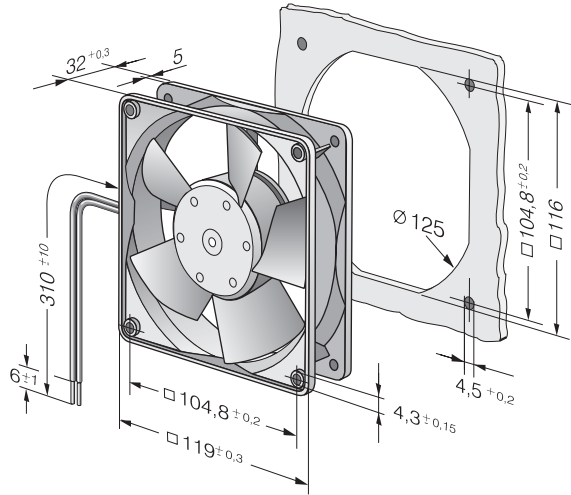

4312 T

DC axial compact fan

Connection screen

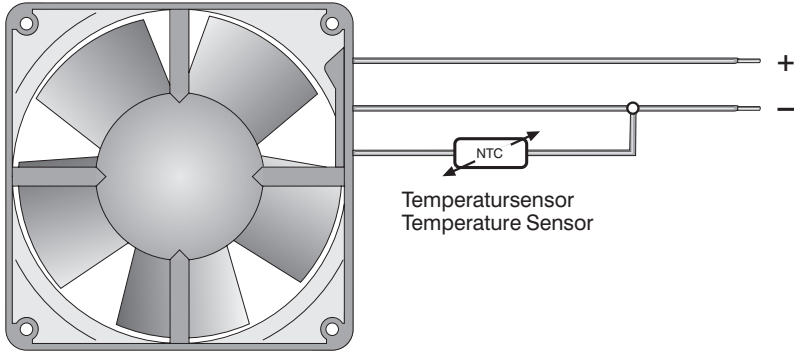

Charts: Air flow

